

New Zealand Industry Code of Practice
NZ-ICP-003a

**Window and Door Hardware in Housing
and Residential Buildings
Product Performance – Structural Strength**



Window & Glass Association New Zealand
PO Box 44 237
Pt Chevalier
AUCKLAND 1246
New Zealand

Change Register	
1 May 2019	Published
1 July 2026	Logo updated and section 5.3 updated with images including Association logo removed

PREFACE

This Industry Code of Practice was prepared by the Window & Glass Association New Zealand.

The goal of this document is to be a generic code, applicable to a range of hardware on residential windows and doors.

- It should provide customers and consumers a means of selecting hardware.
- This document covers primarily the structural strength requirements of hardware in Housing and Residential Buildings.
- These performance requirements were selected as they affect the longevity of the hardware and impact on the overall performance of window systems
- This code should be used in conjunction with TT-ICP-002; Window and Door Hardware in Housing and Residential Buildings; Product Performance – Durability and Corrosion Resistance.
- This document is not intended to replace the performance requirements for window and door systems as covered by NZS 4211, although it may be considered as a means of determining hardware suitability for system testing.

INTERPRETATION

If there are any concerns regarding interpretation of this Code of Practice, they should be referred to the Window & Glass Association NZ.

USING THIS DOCUMENT (NZ-ICP-003a)

This ICP must always be referred to in full as:

**Window and Door Hardware in Housing and Residential Buildings
Product Performance – Structural Strength**

SUBSTITUTION

This document is designed to provide comparison of performance between one item of hardware and another. It cannot however be the basis for substitution between items of hardware in a given window or door system. The final determination of whether hardware is suitable and whether the window and door system complies with NZS 4211 or other requirements is the responsibility of the window or door manufacturer or system supplier.

MAINTENANCE

Routine preventative maintenance in accordance with the manufacturer's instructions is essential to ensure that hardware products achieve their intended useful life.

CONTENTS

SECTION 1	SCOPE AND GENERAL	4
1.1	GENERAL	
SECTION 2	TESTS	6
2.1	GENERAL	
2.2	STRUCTURAL PERFORMANCE	
2.3	EASE OF OPERATION	
2.4	TEST FLOW CHART	
SECTION 3	TEST CONDITIONS	10
3.1	GENERAL	
3.2	STRUCTURAL PERFORMANCE	
3.3	EASE OF OPERATION	
SECTION 4	PERFORMANCE REQUIREMENTS	12
4.1	GENERAL	
4.2	STRUCTURAL PERFORMANCE	
4.3	EASE OF OPERATION	
SECTION 5	LABELLING AND CERTIFICATION	15
5.1	GENERAL	
5.2	CERTIFICATION	
5.3	LABELLING	
APPENDIX A	FIT FOR PURPOSE (INFORMATIVE)	16
APPENDIX B	TEST PROCEDURES	17

Window & Glass Association New Zealand

New Zealand Industry Code of Practice

Window and Door Hardware in Housing and Residential Buildings Performance and Specification

SECTION 1 - SCOPE AND GENERAL

1.1 GENERAL

This document specifies the test conditions and performance requirements to use as a benchmark for hardware used on external windows and doors in housing and residential buildings as they are defined in the New Zealand Building Code.

Structural Strength refers to the stresses the system will undergo due to negative and positive pressures caused by weather. It does not cover Forced Entry resistance.

The scope and use of this document are limited to Window & Glass Association NZ members only. Only Association members may use and claim compliance with this document.

1.2 SCOPE OF WINDOWS AND DOORS

This document is applicable for hardware for the following types of windows and doors-

- a) sliding sashes,
- b) folding sashes,
- c) casement sashes (including swinging sashes),
- d) awning sashes,
- e) hung windows,
- f) louvre windows

Where 'sashes' denotes both windows and doors.

1.3 SCOPE OF HARDWARE

This document is applicable to the following hardware**,

- a) locks,
- b) latches,
- c) stays,
- d) hinges,
- e) rollers,
- f) pivots,
- g) operators,
- h) winders,
- i) restrictors,
- j) window fasteners,
- k) balances,
- l) door handles,
- m) flushbolts,
- n) bottom rollers,
- o) folding door pivots/bogies

1.4 REFERENCED DOCUMENTS

This document references the following documents-

- a) NZS 4211 Specification for Performance of Windows
- b) AS 4145 Locksets
- c) NZBC New Zealand Building Code

1.5 CERTIFICATION PROCEDURE

Companies seeking certification of hardware to this document must follow the procedure described below-

- a) Test hardware according to the tests described in Section 2 in the order described in 2.4 Test Flow Chart
- b) Perform those tests according to the test conditions described in Section 3
- c) Meet the performance requirements described in Section 4
- d) Apply labelling and supply certification as described in Section 5.

1.6 DEFINITIONS

For the purpose of this document, the definitions given in NZS 4211, AS 4145.1 and those below apply-

- 1.6.1 Accredited test facility - a test facility accredited to perform a given test by a third party accreditation body complying with ISO/IEC 17025
- 1.6.2 Association - Window & Glass Association New Zealand
- 1.6.3 Fit for Purpose - refer to Appendix A
- 1.6.4 Fixture - a small section of a typical window or door to which the samples are mounted
- 1.6.5 Suitably Qualified Person – see definition in Section 2 of NZS 4211:2008: “A person with the skills, experience and qualifications necessary to assess and determine compliance”.
- 1.6.6 Hardware Company – the manufacturer, supplier, distributor or individual who is seeking certification of hardware to this document.
- 1.6.7 Sample - all the components and multiples of the product that are required for testing.
- 1.6.8 Handles – for the purposes of this document, handles can be defined as furniture designed for the purpose of activating a lock or latch of some description.

1.7 FALSE CLAIMS

Potentially false claims brought to the attention of the Association Board will be investigated, and if determined to be false, procedures for redress will be undertaken.

SECTION 2 – TESTS

2.1 GENERAL

Samples of the hardware within the scope of Section 1 for which certification is being sought shall be subject to various tests. It is not appropriate to subject all hardware types to all of the tests described. Prior to starting the testing programme, the applicable tests should be determined using the testing segregation table in section 2.1.1 below. Once the relevant tests have been determined they are to be performed consecutively and cumulatively according to the tests shown in 2.4 Test Flow Chart.

This document is applicable for testing hardware that is in its nominally closed position, whereby it is assisting the window or door system to withstand the conditions experienced in weather performance testing. Open sashes negate the effects of negative pressure.

2.1.1 Testing Segregation

The testing segregation table should be used in conjunction with the two streams of tests shown in 2.4 Test Flow Chart, to determine the relevant test schedule for the hardware item to be tested.

Hardware Type	Structural - Service	Ease of Operation	Structural - Ultimate
Locks**	✓	✓	✓
Latches**	✓	✓	✓
Stays	✓	✓	✓
Stays – Non Friction	✓	✓	✓
Hinges	✓	✓	✓
Rollers	✓*	✓*	✓*
Pivots	✓	✓	✓
Operators	✓	✓	✓
Restrictors	✓*	✓*	✓*
Window Fasteners	✓	✓	✓
Closers	✓*	✓*	✓
Balances	✓*	✓*	✓*
Door Handles	x	x	x
Flushbolts	✓	✓	✓
Folding Door Pivots/Rollers/Bogies	✓*	✓*	✓*
Multipoint Window Fasteners	✓*	✓*	✓*

*If applicable.

Rollers, Restrictors, Closers, Balances and Door Handles are examples of hardware that may not typically be considered as being vulnerable to the effects of negative or positive pressures. However, in some circumstances it may be applicable to test these products structurally, for example:

- if a roller is not captive in a track system
- If a restrictor is used to hold a sash closed
- If a balance is the primary means of restraining a sash
- If a closer is also a door pivot

** Locks and Latches will include Multipoint systems as the rod tips will resist negative/positive pressures. Locks and latches are to be tested with an appropriate means of actuating the product – for example; cylinders, snibs, escutcheons and furniture (handles). It is permissible to test “kits” of hardware, but this must be disclosed on relevant test reports and certificates.

2.1.5 Type-testing of similar products

Groups of similar products which are mechanically equivalent, for example left and right handing or colour variations in the same finish may be type-tested to determine performance of the whole group. Note that material variances, for example plastic colour or material purity, could affect the performance of the product. For example, two products can appear to be identical but, depending on these variances, the structural strength can vary considerably between them.

2.1.6 Test Facilities

It is a requirement that the tests be performed in a test facility as defined. This requirement is specified in the relevant tests described in this section. Each stream of testing shall be performed within the one test facility. That test facility is responsible for the handling, storage, safety and confidentiality of the hardware samples and intellectual property.

2.1.7 Testing Safety

The testing described in this document involves procedures and equipment that are potentially dangerous to those performing the tests, bystanders and facilities. Care should be undertaken before testing commences to ensure that all potential dangers to people and facilities are minimised. Testing should only then be performed by persons trained in the safe operation of the required equipment.

This document does not describe the safety equipment and practices necessary; this information should be obtained independently.

2.2 STRUCTURAL PERFORMANCE TEST

The test sample shall be subjected to the structural performance loading under the test conditions in 3.2 and must pass the performance requirements in 4.2 before proceeding to the next test.

2.3 EASE OF OPERATION

The test sample shall be subject to the relevant operating forces described in 3.3 and must pass the performance requirements in 4.3 as dictated by the Test Flow Chart in 2.4.

2.4 TEST FLOW CHART

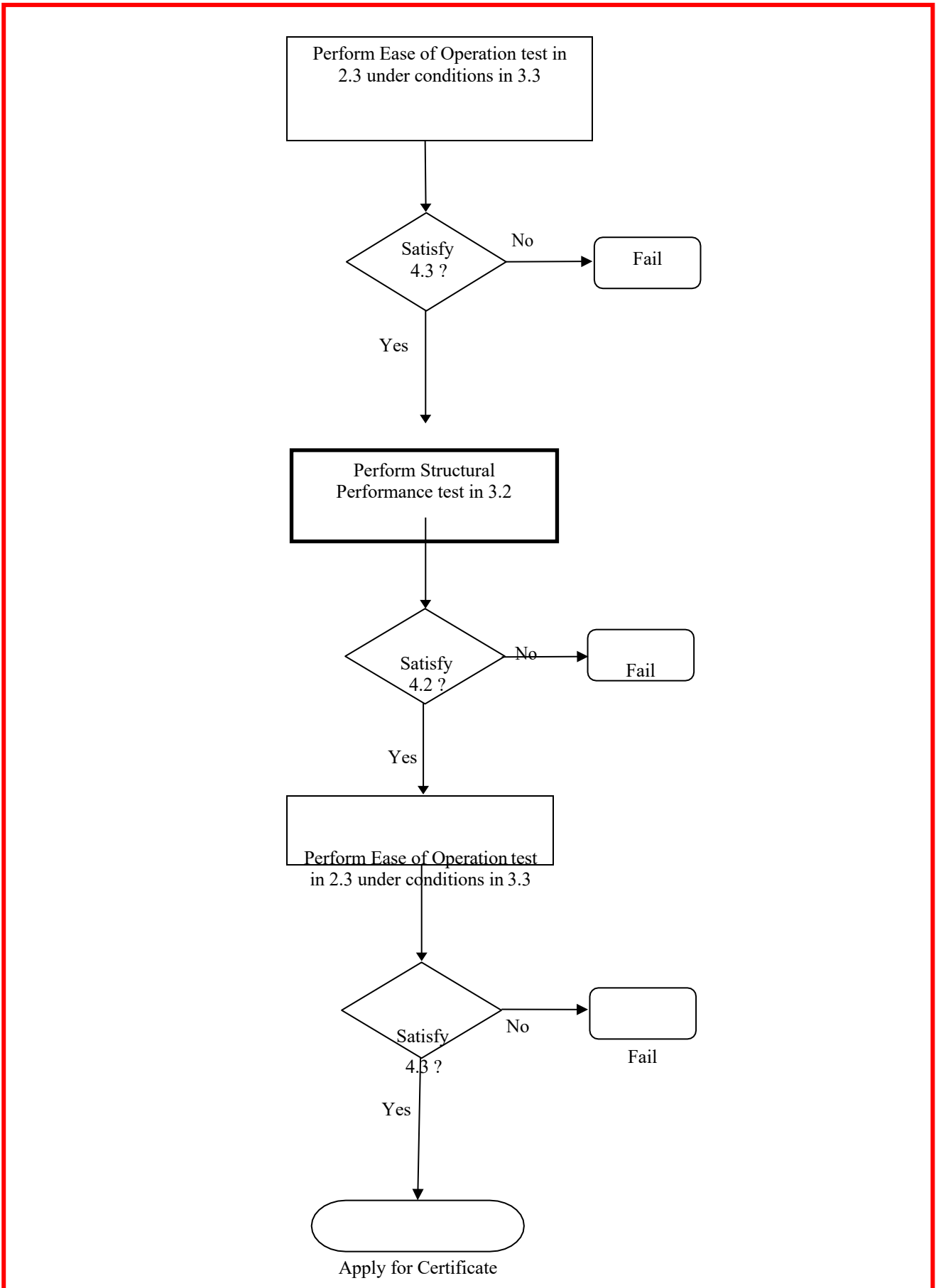

SECTION 3 - TEST CONDITIONS

3.1 GENERAL

The tests described in Section 3 shall be performed under the following conditions. During these tests and within the test conditions specified, reasonable effort shall be made to replicate the conditions of actual field use regarding the installation and operation of the samples.

The test rig described in the Appendix of this document may be the same test rig used in the Ease of Operation test 2.3. Thought should be given to the construction and flexibility of this rig to ensure it can meet the variety of tests it must perform.

If the samples are to be lubricated as part of the product's instructions, then lubrication may only be applied before any testing commences and may not be reapplied at any time thereafter.

3.2 STRUCTURAL PERFORMANCE TEST

The test sample shall be subject to the forces applied in a direction and manner which simulates serviceability wind pressure on a typical sash.

Where a product is not subject to or not designed to resist the forces generated by wind pressure, this test shall not be performed on the samples and the Wind Strength applied to that product shall be recorded in newtons (N).

3.2.1 Sample preparation

The samples shall be mounted to fixtures that simulate their typical installation. This includes the fixing method, fixing hardware, those surfaces totally shielded in a typical installation and those surfaces partially shielded in a typical installation.

3.2.2 Rated size, weight

Each sample shall be mounted to a test rig that simulates its typical installation in accordance with the product's instructions. This includes the fixing method and the fixing hardware.

The sash of this rig shall be the maximum size and weight for which the hardware is rated by the manufacturer or a rig that simulates the maximum size and weight. See Appendix.

3.2.3 Clearances

The samples shall be installed to hold the sash and frame of the cyclic test rig within the clearances stated in the product's instructions.

3.2.4 Loading

The load shall be applied using a suitable, measurable load application device such as a load cell and hydraulic or pneumatic ram. The load should be applied linearly over a period of approximately 60 seconds up to the maximum loading designated for the particular item of hardware being tested and held at that force for 10 seconds.

3.3 EASE OF OPERATION

The test sample shall be operated and have the operating force measured.

The test shall be performed with the samples mounted to same test rig used in the Cyclic Loading test (described sub-section 3.3.1 in TT-ICP-002), in the same manner.

The actuating mechanism of the test rig shall be removed or disconnected to allow the sash to be freely operated.

This test is performed twice on the sample, before and after the Structural Performance Test in 2.3. On the first occasion, if the samples are to be lubricated as part of the product's instructions, then lubrication is to be applied before the test. On the second occasion, these samples may not be lubricated or adjusted before or during this test.

SECTION 4 - PERFORMANCE REQUIREMENTS

4.1 GENERAL

Upon successful completion of the tests in Section 3, hardware tested shall meet the following performance requirements

4.2 STRUCTURAL PERFORMANCE TEST

The test samples shall be subjected to forces applied in a manner typical to that applied by wind pressure on a closed sash up to the force to which the hardware is rated by the Hardware Company – See Appendix B.

The test shall be performed with the samples mounted to the test rig described in the Appendix and in the same manner. Ideally, an air pressure booth should be used to apply the forces to the sash, however where this is not possible, the forces may be applied by mechanical actuators that simulate the forces applied by wind pressure.

Although the forces may be applied to the sash at a convenient location, the required force is that exerted on the hardware at the point at which the hardware resists movement of the sash.

The samples must not be lubricated or adjusted before or during this test.

The direction of the forces shall be that which is most aggressive on the hardware. Where applicable, forces generated by both negative and positive wind pressures shall be applied, for example a door roller. The forces shall be applied and steadily increased to the maximum required within 60 seconds and shall be held at that force for 10 seconds.

At the completion of the test described in 3.2, the sample shall-

- a) Not break.
- b) Be fully operable and pass the Ease of Operation test 3.3
- c) All hardware including hardware relying upon friction or resistance to control an opening must still perform its function as intended

The simulated or actual sash weight, the 'as installed' clearances shall be recorded for the test report.

4.3 EASE OF OPERATION

4.3.1 For Locks and Locksets (this includes latches, winders, camlocks etc. that have a key mechanism).

During the test described in 3.3 the maximum measured operating forces shall be in accordance with AS4145.2 to the requirements of Table 4.1.

TABLE 4.1 EASE OF OPERATION – AS4145.2-2008

Locksets excluding keying security	Clause reference		Value for designation
	Requirement clause	Procedure (Appendix A) Paragraph	
<i>Ease of operation</i>			
Torque to retract friction-free bolt— by turnknob by key by knob by lever	3.3.2	A5.1	$D_{\text{knob}} \times 0.05 \text{ Nm max.}$ $D_{\text{key}} \times 0.05 \text{ Nm max.}$ $D_{\text{knob}} \times 0.05 \text{ Nm max.}$ $L_{\text{lever}} \times 0.04 \text{ Nm max.}$
	3.3.2(a)	A5.1	
	3.3.2(b)	A5.1	
	3.3.2(c)	A5.1	
Torque to operate hub locking device	3.3.7	A5.6	$D_{\text{key}} \times 0.05 \text{ Nm max.}$
Torque to retract friction-loaded bolt— by turnknob by key by knob by lever	3.3.4	A5.2	$D_{\text{knob}} \times 0.1 \text{ Nm max.}$ $D_{\text{key}} \times 0.22 \text{ Nm max.}$ $D_{\text{knob}} \times 0.1 \text{ Nm max.}$ $L_{\text{lever}} \times 0.07 \text{ Nm max.}$
	3.3.4(a)	A5.2	
	3.3.4(b)	A5.2	
	3.3.4(c)	A5.2	
Force to latch door	3.3.5	A5.3	20 N max.
Projection of deadlatch plunger to effect deadlocking action	3.3.6	A5.5	4 mm \pm 1 mm

4.3.2 Force to operate hardware by manually operating a sash (to match NZS 4211)

- folding Sashes 30N (applied at edge of sash)
- sliding 30N
- swinging sashes 30N (applied at edge of sash)

4.3.3 Hardware Requiring Loads

- arm winder (e.g casement) 2Nm
- cam lock 2Nm
- chain winders 2Nm
- sliding window latch 20N (to unlatch only)
- wedgeless keepers 2Nm
- window and door bolts 15N

This excludes hardware specifically designed to resist by friction alone the forces generated by wind pressure such as casement or awning friction stay.

Maximum force to operate hardware by manually operating a sash where the hardware is specifically designed to resist by friction alone the forces generated by wind pressure-

- swinging sashes 90 N applied at edge of sash

Where friction restraints alone are relied on to control an open, pivoted or projected sash, they shall provide sufficient restraint to prevent the window from moving when a force (in newtons) equal to 35 times the sash area in m² is applied to the edge furthest from the

This force shall be applied perpendicularly to the plane of the sash at all angles of opening to 70% of the maximum opening distance.

These forces are for the operation of the hardware alone, without any friction imposed by seals or other hardware not part of the sample being tested.

The force(s) required to operate the hardware in newtons and newton metres (whether tension, compression or torque) shall be recorded for the test report.

SECTION 5 - LABELLING AND CERTIFICATION

5.1 GENERAL

Hardware packaging and or literature may be labelled. Labels shall be in accordance with Clause 5.3. Hardware claiming compliance or labelled as compliant to this ICP shall be supported by a certificate as per Clause 5.2

5.2 CERTIFICATION

The following minimum information shall be stated on the compliance certificate as per Appendix A

- Industry Code of Practice Number
- Date of certificate
- Identification of testing report number traceable to ISO 17025
- Name of Manufacturer or supplier of hardware and contact information
- Product description and detail including part number(s) identification
- Product capacity or size specification as tested
- Product type as specified in clause 1.3
- Product performance ratings
 - Corrosion Resistance Category
 - Cyclic Loading Performance Grade

5.3 LABELLING

The Label shall contain the following information

- a) the manufacturer's identification mark or name
- b) test report number and date
- c) the corrosion grade
- d) the cyclic performance grade
- e) Product capacity or size specification as tested

APPENDIX A: FIT FOR PURPOSE (INFORMATIVE)

A1 GENERAL

Hardware should be fit for those purposes and applications for which the Hardware Company recommends its use.

a) “Fit for Purpose” Definition

Hardware that is designed and constructed in a quality manner that will meet the intended purpose as set forth by the manufacture.

A2 FIT FOR PURPOSE CONSIDERATIONS

In addition to the legal definition, ‘Fit for Purpose’ within this document and for the scope of hardware it covers means the following within the product’s nominal life-
The following functional aspects of fit for purpose should be considered

a) Structural Failure

The hardware shall be operable without permanent deformation or breakage. The hardware shall withstand the forces generated by wind pressure on a sash up to the force to which the hardware is rated by the Hardware Company and remain serviceable.

b) Secondary Damage

The hardware shall allow the sash to operate without causing damage to any element of the window or door opening.

c) Operation

The hardware shall allow itself and the sash to operate through the functions and movements for which their design provides, across the full range of sash loads for which the hardware is recommended.

d) Security

Where applicable, the hardware shall provide a level of security suitable for the applications for which the hardware is recommended by the Hardware Company (reference can be made to a product’s performance under AS 4145 or other appropriate standard).

e) Noise

The hardware shall be operable without causing excessive noise which would not normally or reasonably be associated with that type of hardware.

f) Safety

The hardware shall be safe to operate and must not represent a danger to a person.

APPENDIX B: TEST PROCEDURES

B1 SIMULATED SASH PANEL TEST RIG

Tests for several hardware items can be performed in a simulated sash panel rig consisting of a frame portion and separate sash portion.

The section used shall be of sufficient size that hardware components requiring testing will fit within it, with a similar level of support that they would experience if mounted to a window or door system. The hardware to be tested shall be mounted within the sash or frame in a similar position and orientation to a real window or door system.

The gap between the sash panel and the frame shall be equivalent to the gap specified for the hardware being tested.

The force shall be applied with a calibrated and certified load cell mounted to the centre of the sash panel and supported by the frame.

The edge of the frame where the hardware is mounted and the two adjacent edges shall be supported solely by the hardware in its standard closed/locked configuration, with the opposite edge supported by a rigid element preventing linear movement of the sash along that edge.

Simulated Sash Panel Construction

The simulated sash panel shall measure 1200 x 600 and shall be constructed in such a way that it will be unaffected by the forces it is likely to be subjected to during simulated negative pressure testing and testing of the hardware to ultimate failure. It is recommended that the rig frame and sash is constructed from rectangular hollow section steel or aluminium of sufficient gauge and dimensions to achieve this.

B1a Hinged Door Locks

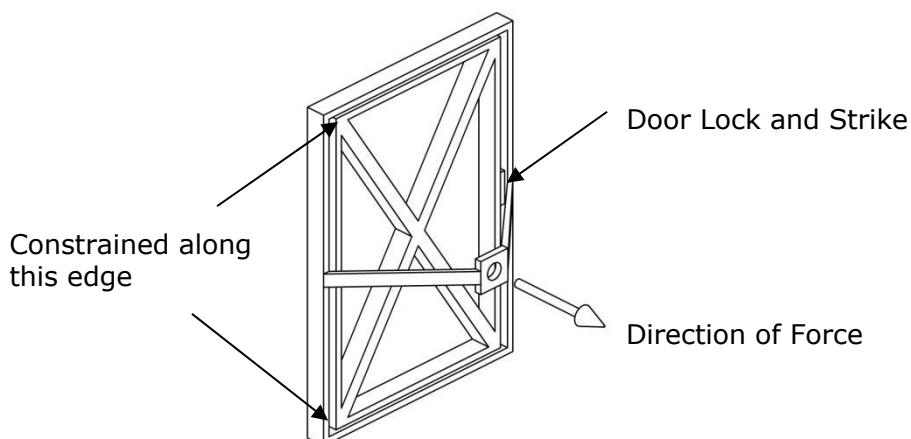

Simulated Negative Pressure Testing of Hinged Door

B1b Hinges

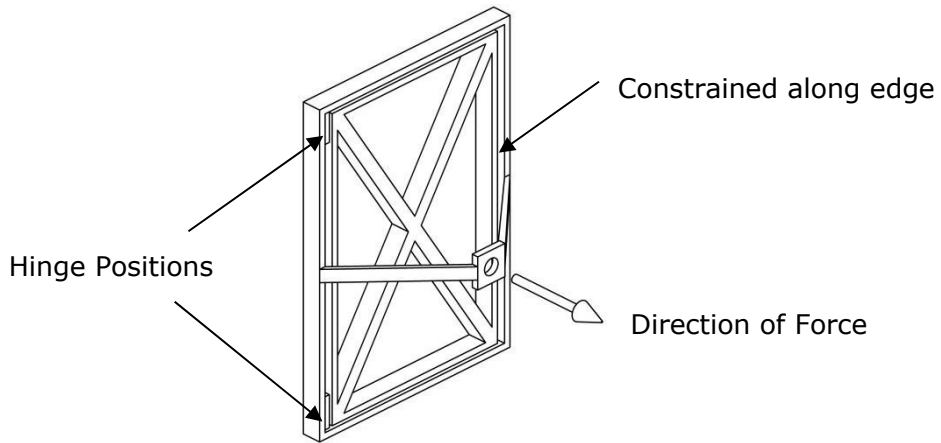

Negative Pressure Testing of Hinges

B1c Friction Stays

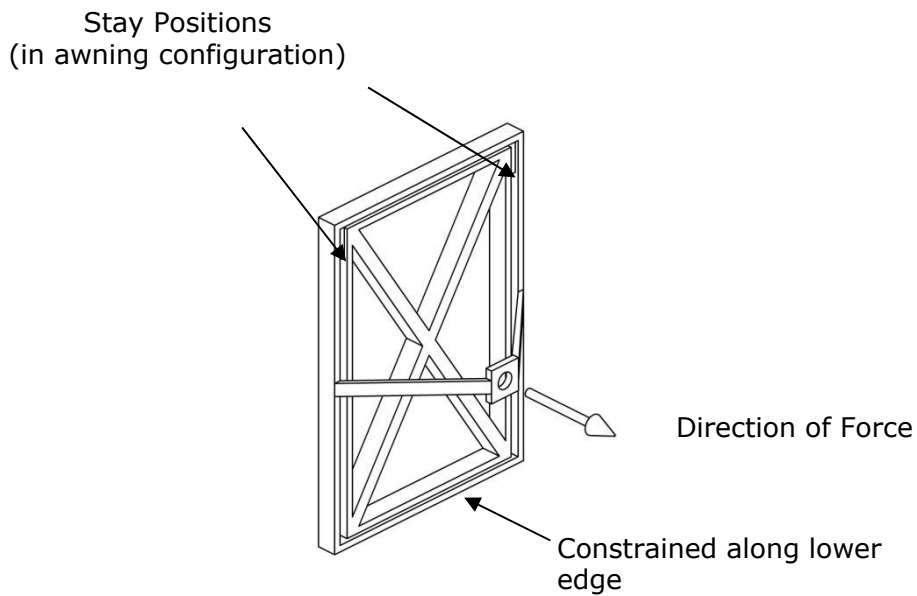

Negative Pressure Testing of Window Stays

B1d Pivots

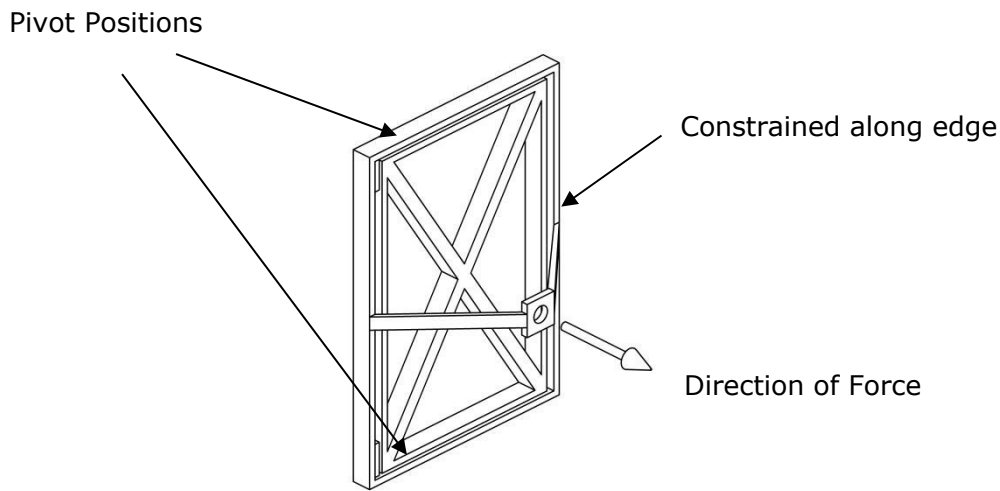

Negative Pressure Testing of Pivots

B2 FLUSHBOLT TIPS/BIFOLD LOCK ROD TIPS*

*Rod tips, for the purposes of this document, are defined as the component of the lock system that spans the gap between the top or bottom of the door, where they may be controlled in a rod guide, and the frame head or sill where they will engage in a channel or strike when in the locked position to hold the sash closed. Place the bolt shear test rig, specimen and large capacity calibrated load cell into compression testing machine. See diagram. The two plates must be separated by a gap between the two plates, which shall be equal to the standard gap at the head or sill of the door – whichever is greater.

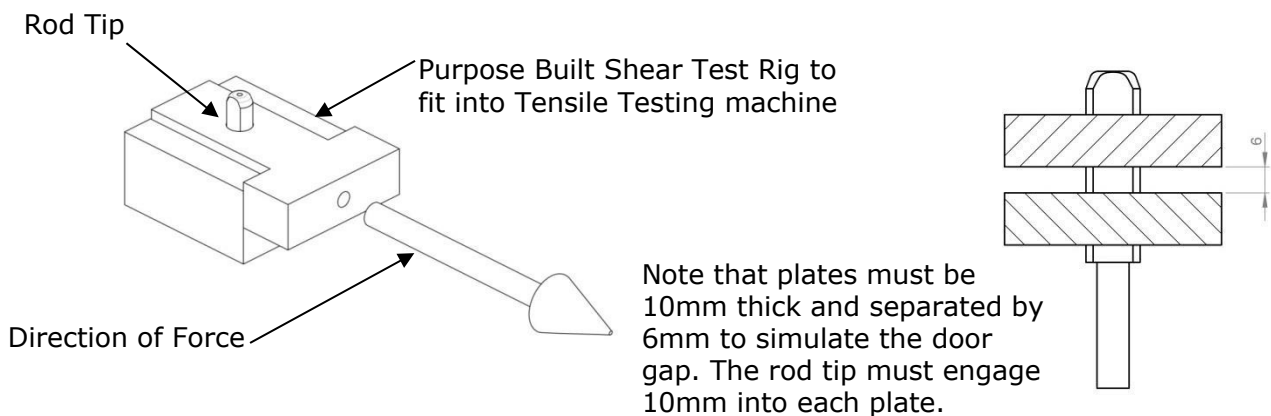

Negative Pressure Testing of Flushbolt Tips/ Rod Tips

B3 WINDOW FASTENERS

Fit window fastener to tensile test rig as per installation instructions. Engage fastener such that the tongue fits over the upstand on the sliding part of the rig. This is what constrains the fastener from opening.

Attach sliding part to the calibrated load cell in the tensile test rig. See diagram.

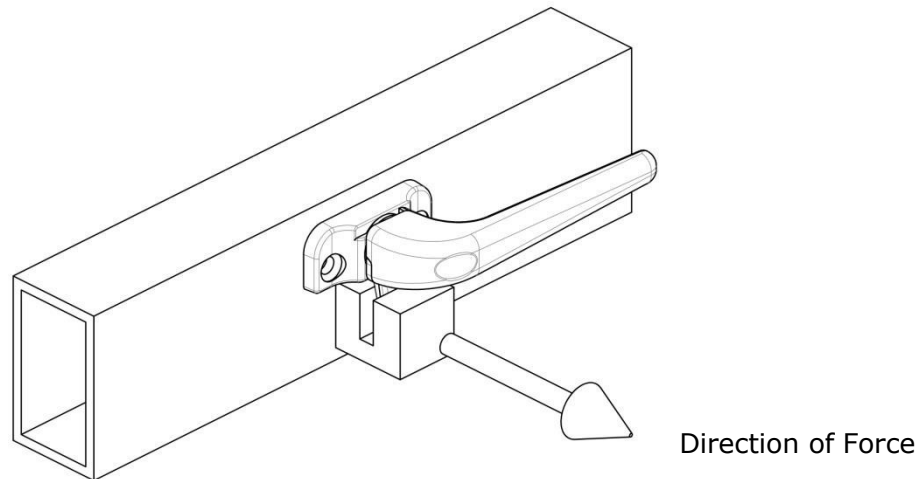

Negative Pressure Testing of Window Fasteners

Note that the test rig may need to be modified or redesigned to suit future developments in window hardware. Such a test rig must be compatible with the product design and simulate the effect of negative or positive pressure on the hardware. The Association is to be advised of any test rig that needs to be modified or redesigned. A suitable piece of testing equipment for hardware not already covered in this document, must be presented for review as part of a test report.

B4 OPERATORS and CHAIN WINDERS

This procedure is designed for use with motorised window operators, but the principal applies to self-contained mechanical driven devices (including Chain Winders) that can be parked in a closed position.

Fit window operator to mounting plate in tensile test rig as per installation instructions. Drive operator to closed position and connect a calibrated load cell via an adaptor. See diagram.

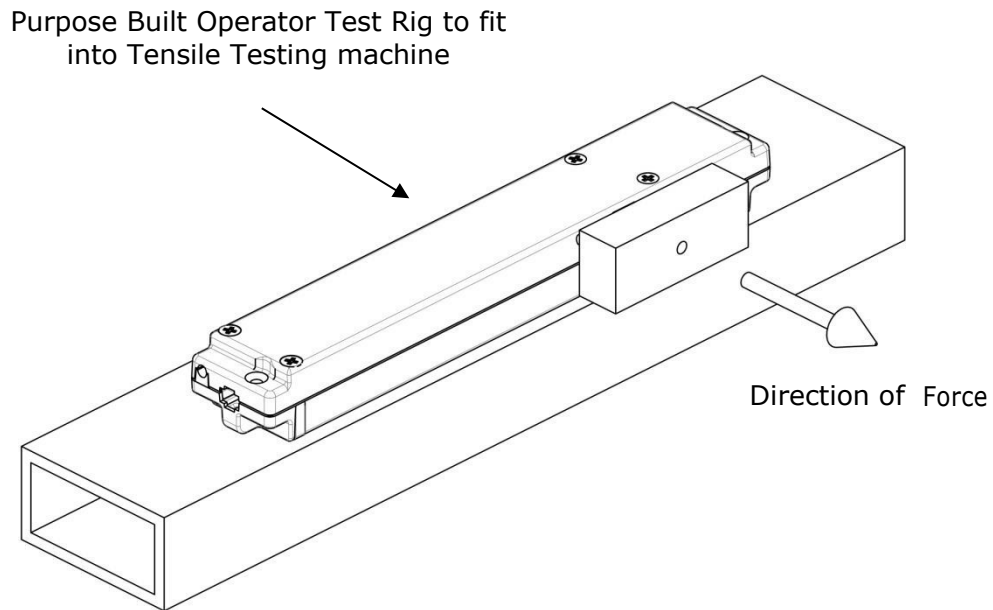

Negative Pressure Testing of Window Operators

B5 FOLDING DOOR HARDWARE

Include appropriate test for folding door hardware in particular boogies, bottom rollers and guides – if the hardware is system specific, a NZS 4211 test shall be conducted. The name, location and registration number of the laboratory used, and the test number and date shall be included for traceability.

B6 PRESSURE LEVELS – FORCE EQUIVALENTS for STURUCTURAL PERFORMANCE TESTING

Equivalent force values for NZ-ICP-003a See equivalent table for Endurance (D1 - D10) in TT-ICP-002 page 15		HINGED DOOR LOCKS*	HINGES*	PIVOTS*	ROD TIPS*	FOLDING DOOR HARDWARE*	FRICTION STAYS*	WINDOW FASTENERS*	OPERATORS AND CHAIN WINDERS*
RATING	FORCE (N)**								
S1	500	Min	Min	Min	Min	System Specific	Min	Min	Min
	1000								
S2	1500								
	2000								
S3	2500								
	3000								
S4	3500								
	4000								
S5	4500								
	5000								
S6	5500								
	6000								
S7	6500								
	7000								
S8	7500			Min					
	8000								
S9	8500								
	9000								
S10	9500								
	10000								
S1									
**Force includes statistical factors based on NZS 1170 and is based on using the testing apparatus described in Appendix B									